

Standard values for the machining of copper and copper alloys

Published by:
German Copper Institute
Information and Advice Center for
the Use of Copper and Copper
Alloys
Copper and Copper Alloys

Am Bonneshof 5
40474 Düsseldorf
Telephone: (0211) 4 79 63 00
Fax: (0211) 4 79 63 10
info@kupferinstitut.de
www.kupferinstitut.de

All rights reserved, including those of
partial reprinting and
photomechanical or electronic
reproduction.

Edition 2010 Revised by:
Machine Tool Laboratory
WZL of RWTH Aachen University
Prof. Dr.-Ing Dr.-Ing E.h. Dr. h.c. Fritz Klocke
Dipl.-Ing. Dieter Lung
Dr.-Ing. Klaus Gerschwiler
Dipl.-Ing. Patrik Vogtel
Dipl.-Ing. Susanne Cordes
Fraunhofer Institute for Production Technology IPT
in Aachen
Dipl.-Ing. Frank Niehaus

Picture credits:
TORNOS, Pforzheim; Wieland-Werke, Ulm

We would like to thank the ICA (International
Copper Association) New York for their special
support in the publication of this brochure.

Contents

Table of contents	1	6 Cutting edge geometry	35
Foreword	2	6.1 Chip and clearance angles.....	35
1 State of the art.....	3	7 Cooling lubricants.....	37
2 General principles	5	8 Information on the calculation of machining costs.....	38
2.1 Cutting part geometry and its influence on the cutting process.....	5	9 Ultra-precision machining of copper	40
2.1.1 Cutting part geometry.....	5	9.1 Basics of ultra-precision machining	40
2.1.2 Influence of the cutting part geometry on the machining process.....	6	9.2 Application examples of copper alloys 40	
2.2 Wear on the cutting part	10	9.3 Material properties and influences.....	41
2.3 Chip formation	11	10 Standard values for machining copper and copper alloys of copper and copper alloys	43
3 The term machinability.....	13	10.1 Turning copper materials	43
3.1 Evaluation parameter tool life.....	13	10.2 Drilling and countersinking copper materials	44
3.2 Cutting force	15	10.3 Reaming copper materials	46
3.3 Evaluation parameter surface quality.....	18	10.4 Tapping and thread milling of copper materials.....	46
3.4 Evaluation parameter chip shape.....	21	10.5 Milling of copper materials	47
4 Classification of copper materials according to machinability groups	23	11 Machining pattern applications	49
4.1 Standardization of copper materials.....	23	12 Formulas	56
4.2 Assessment criteria for machinability.....	23	12.1 Equations.....	56
4.3 Influencing machinability through casting casting, cold forming and hardening.....	24	12.2 Formula symbols / Symbols and abbreviations.....	58
4.4 Influence of alloying elements on machinability.....	25	13 Literature / Standards and guidelines	61
4.5 Classification of copper materials into main groups of machinability.....	28	14 Publishing program	64
5 Cutting materials.....	32		
5.1 High-speed steel	32		
5.2 Carbides (HM)	32		
5.3 Diamond as a cutting material.....	33		
5.4 Choice of cutting material	34		

Foreword

The German Copper Institute is continuing an old tradition with the "Guideline values for the machining of copper and copper alloys". For the first time in 1938 the publication "The machining of copper and copper alloys" was published for the first time in 1938. The brochure "Die spanab-hebende Bearbeitung von Kupfer und Kupferlegierungen" (Machining of copper and copper alloys), which was completely redesigned by J. Witthoff at the time, was published in 1956. For the first time, the publication included a complete presentation of all standardized copper materials and the machining data known up to that time. In addition to the highly machinable automotive brass, copper alloys developed for special applications and often difficult to machine were also included. In 1987, the brochure entitled "Guideline values for the machining of copper and copper alloys" was re-published and was substantially restructured and revised by the graduate engineers Hans-Jörn Burmester and Manfred Kleinau. The brochure contained guideline values for the machining of a wide range of copper alloys for all relevant manufacturing processes.

In order to take account of further technical developments, the brochure has been updated and revised while retaining the title "Guideline values for the machining of copper and copper alloys".

Like its predecessors, this brochure is primarily aimed at practitioners. It is intended to help them solve machining tasks as productively and economically as possible. It is also intended to help designers and development engineers to compare different materials in terms of their machinability and thus estimate the corresponding production costs for a component. For this purpose, a machinability index has been added to the table. This is already widely used in the literature and not only helps to compare copper materials with each other, but also enables a comparison with other metallic materials such as steel or aluminum.

In addition, the tables with the material standards have been updated and the guide value tables for the individual manufacturing processes have been revised and supplemented. As machinability is very complex and depends on a whole range of boundary conditions, the guide values given can only serve as orientation values. In order to find the optimum machining parameters for your own production and thus achieve the highest possible level of productivity and cost-effectiveness, it is still essential to carry out additional machining tests under the actual boundary conditions.

1. State of the art Technology

Compared to other metallic construction materials, most copper-based materials are easy to machine. CuZn39Pb3, free-cutting brass, has proven itself for the production of all types of shaped turned parts. The good machining properties of this copper-zinc alloy are so well known that they are often used as a benchmark for describing the machining properties of copper and copper alloys.

Compared to steels and aluminum alloys of the same strength, the machinability of copper alloys is many times better, Fig. 1. This is also reflected in the significantly lower cutting forces, Fig. 2. Unless specific technical requirements preclude the use of CuZn39Pb3, contract turning shops, barrel and automatic turning shops prefer to use this material. Copper materials are generally used

generally used for series-produced components. In order to meet a wide range of technical requirements, a variety of copper materials have been developed over time, such as low-alloyed copper alloys, copper-nickel alloys and new silicon-containing copper alloys. The range of materials extends from high-strength copper-aluminum alloys to very soft, pure copper grades with high elongation at break.

Due to the different mechanical and physical properties, the machinability varies from material to material. Many processors have only incomplete knowledge of the machining behavior of the less frequently used copper materials. For this reason, the machining data used for one and the same material often differs considerably from one manufacturing company to another. The demand for standard

values and machining suggestions for machining production remains high - not least because of the progress made in the cutting sector. In addition, the optimization of machining tasks through the correct selection and coordination of machining data in series production, i.e. for high quantities, is of great economic importance. Material developments are aimed at constantly improving material properties. In order to reduce the cost of machining, materials with improved machining properties are often required without significantly affecting the mechanical or physical properties. An example of this is the development of CuTeP and CuSP. As pure copper has very high conductivity values, but is difficult to machine due to long filaments or tangled chips, tellurium, sulphur and sulphuric acid were added to pure copper.

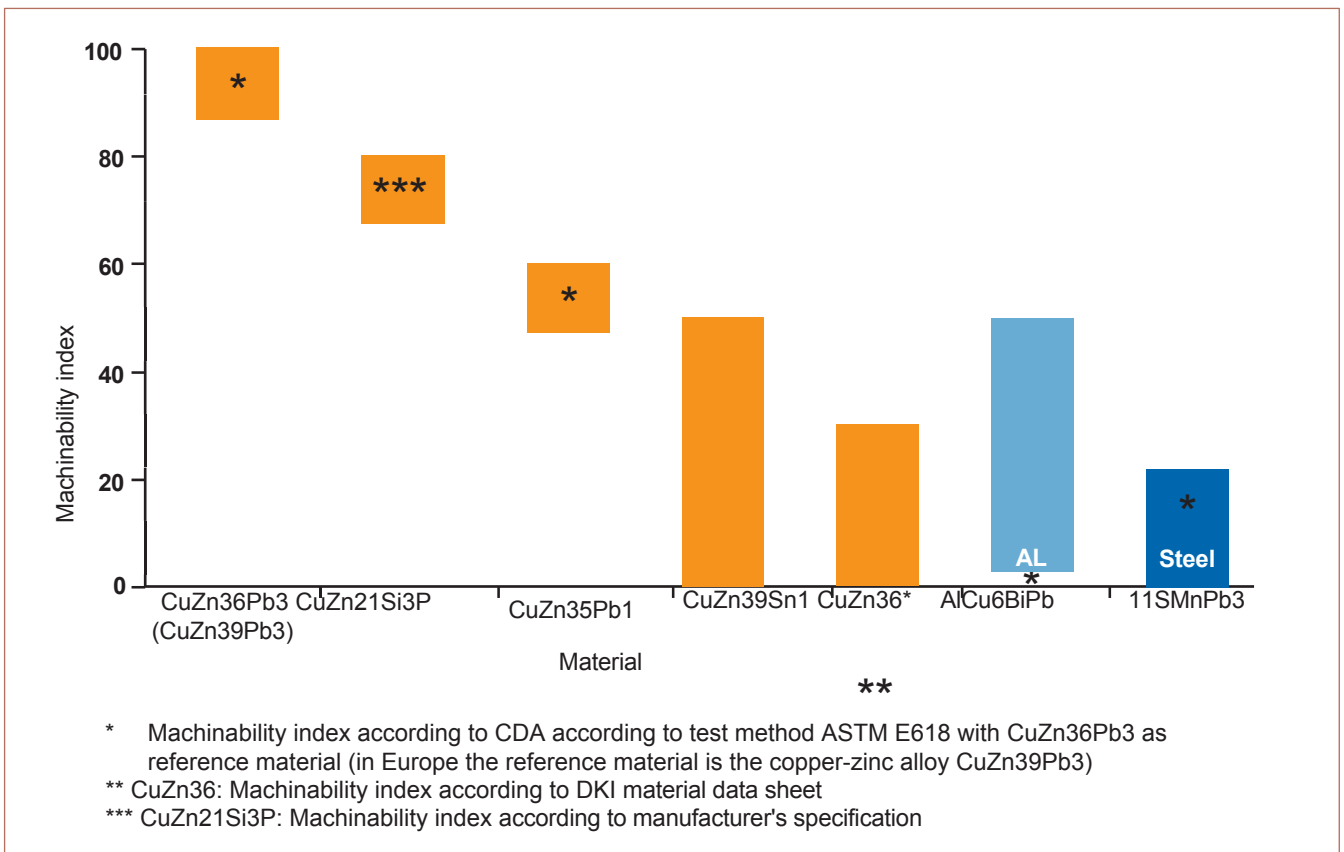

Fig. 1: Comparison of the machinability of copper mill alloys with a free-cutting steel and an aluminum alloy [1, 2, 3].

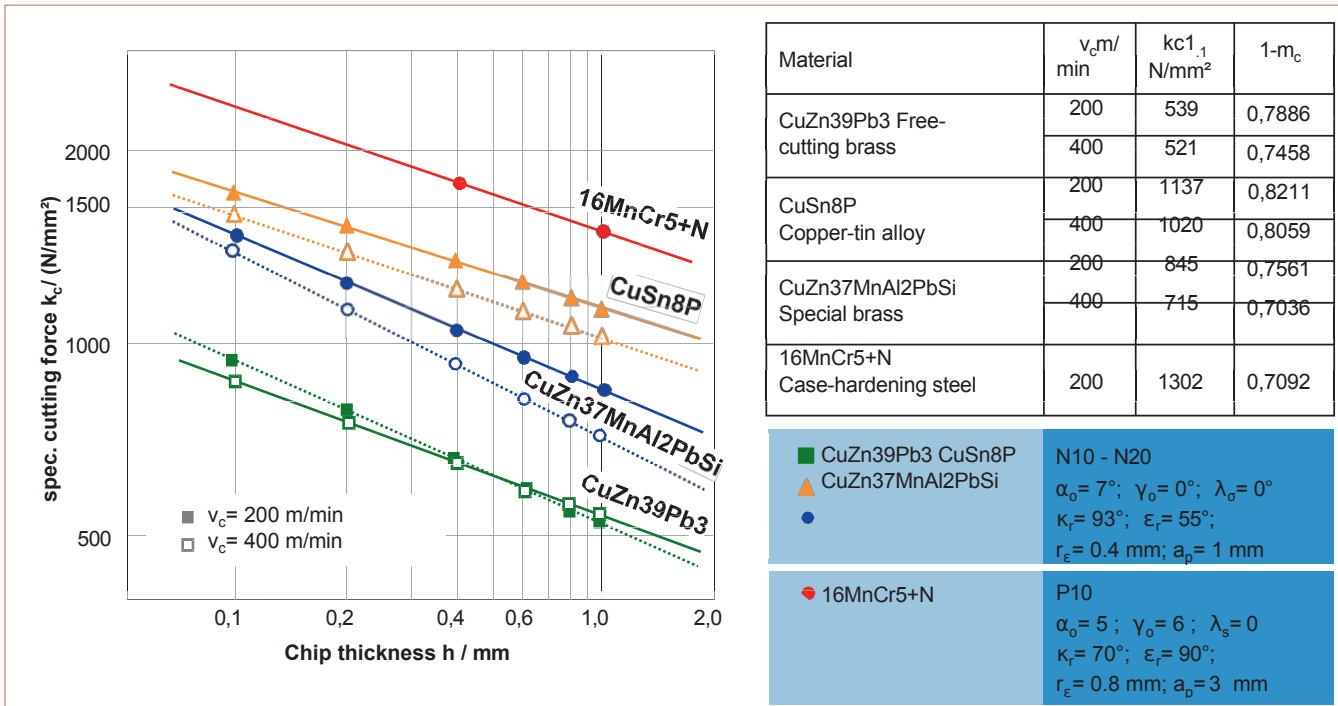

Fig. 2: Comparison of the specific cutting force of three copper alloys with a case-hardening steel according to investigations by the DKI and [4]

or lead are added as chip-breaking alloying elements. This means that machining is also possible on automatic machines, whereby only slightly decreasing conductivities have to be accepted.

The continuous improvements achieved in the material and tool (cutting

(cutting material) sector make it difficult for manufacturers to provide cutting value recommendations or guide values over a longer period of time.

The guide values presented in this paper are intended to make it possible to approach optimum cutting conditions, supported or verified by some specific cutting tests.

conditions. For smaller production quantities, the guide values should already be sufficient to solve the machining tasks satisfactorily.

2. General Basics

The basic concepts of machining with regard to cutting part geometry, tool wear and chip formation are explained below using the example of the turning tool. They apply analogously to any other machining process with a defined cutting edge. Knowledge of the basic terms is the basis for understanding the cutting properties of copper and copper alloys.

2.1 Cutting part geometry and its influence on the machining process
The basic terms of machining technology are standardized in DIN 6580, DIN 6581, DIN 6583 and DIN 6584.

The surfaces and cutting edges on the turning tool is shown and explained in Fig. 3.

2.1.1 Cutting part geometry

As Fig. 3 shows, the cutting part of a cutting tool is made up of a rake face, main clearance face and secondary clearance face. The tool angles are determined by the position of these surfaces in relation to each other.

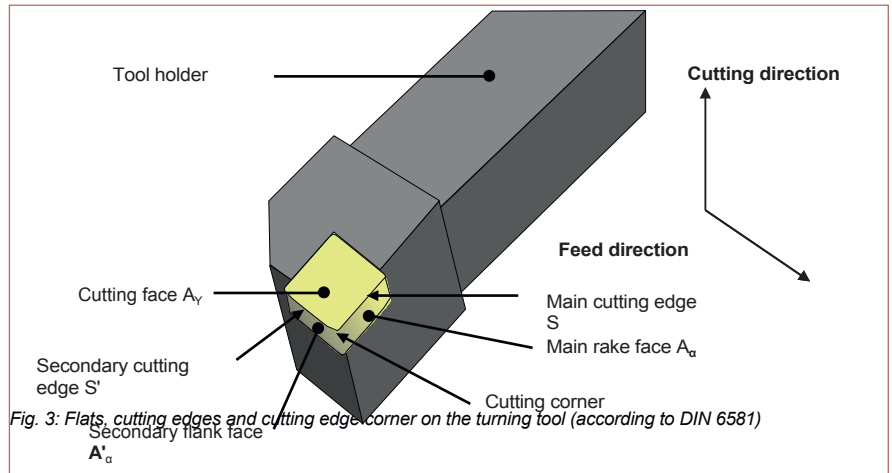

To explain terms and angles on the cutting part, it is helpful to distinguish between the tool reference system and the effective reference system (Fig. 4). These systems are based on different reference planes that are at right angles to each other.

The effective reference system is based on the relative speeds occurring during the cutting process between the cutting

relative speeds occurring between the cutting part and the workpiece during the cutting process. The effective reference plane P_{re} passes through a selected point on the cutting edge and is perpendicular to the effective direction. The direction of the effective direction is the result of the cutting and feed speed.

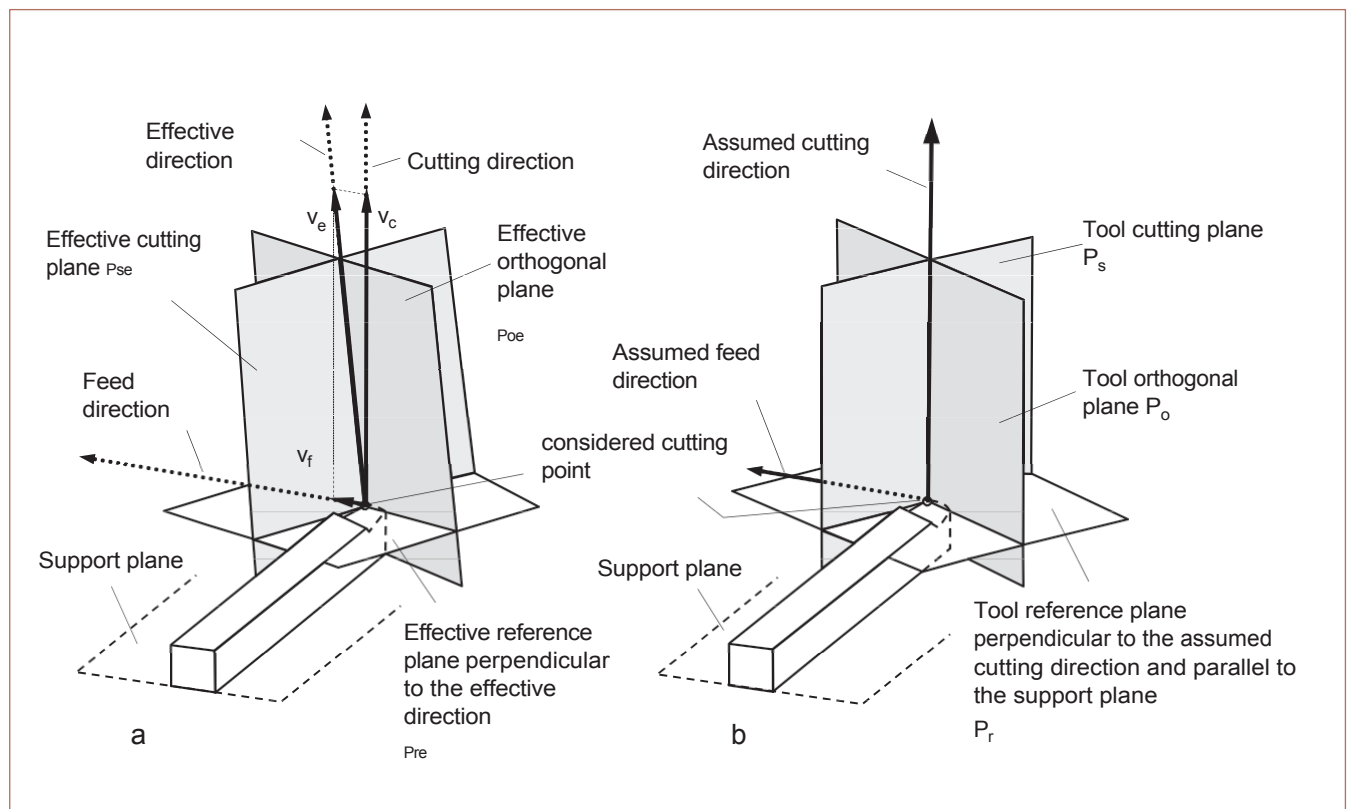

Fig. 4: (a) Effective and (b) tool reference system (according to DIN 6581)

In the tool reference system, the tool reference plane P_r is parallel to the contact surface of the tool. The tool cutting edge plane P_s is tangential to the tool cutting edge and is perpendicular to the tool reference plane P_r . The cutting part geometry is measured in the tool orthogonal plane P_o .

This runs through the selected cutting edge point, perpendicular to the tool reference plane P_r and perpendicular to the tool cutting edge plane P_s .

In the tool reference system, the following definitions apply to the angles on the cutting wedge Fig. 5:

- The clearance angle α_o lies between the clearance surface A_α and the cutting plane P_s measured in the tool orthogonal plane P_o .
- The wedge angle β_o lies between the flank face A_α and the rake face A_γ , measured in the tool orthogonal plane P_o .

- The rake angle γ_o lies between the rake face A_γ and the tool reference plane P_r , measured in the tool orthogonal plane P_o .

The following relationship always applies to these three angles:

$$\alpha_o + \beta_o + \gamma_o = 90^\circ \quad (1)$$

- The setting angle λ_r is the angle between the assumed feed direction and the tool cutting plane P_s , measured in the reference plane P_r .
- The corner angle ϵ_r is the angle between the tool cutting edge planes (P_s , P_s') of the main and secondary cutting edges, measured in the reference plane P_r .
- The tool inclination angle λ_s is the angle between the main cutting edge S and the tool reference plane P_r , measured in the tool cutting edge plane P_s .

The geometry of a turning tool was chosen to illustrate the terms and angles on the cutting part, as this is the best way to show the variables. In principle, the definitions listed can be applied to all tools with a geometrically defined cutting edge.

2.1.2 Influence of the cutting part geometry on the machining process

The choice of cutting angle is of great importance for the result of the machining process and for the service life of the tools. The more the focus is on the economic efficiency of the machining process, the more important it becomes to determine the optimum cutting part geometry. The stability of the cutting part can be increased by appropriate cutting angles, cutting chamfers and cutting edge rounding.

An optimum cutting wedge geometry must be determined taking into account the requirements and working conditions.

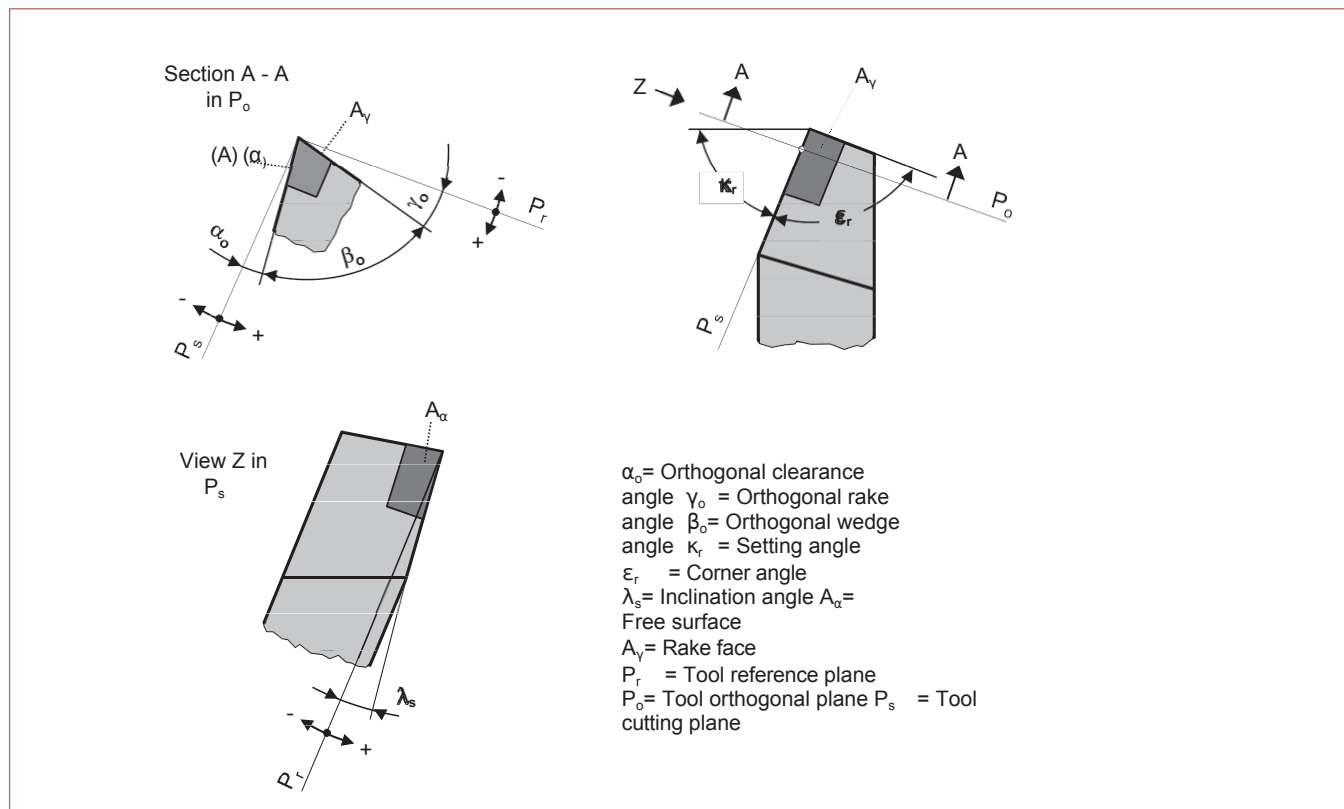

Fig. 5: Most important angles on the cutting part (according to DIN 6581)

It should be noted that all angle changes on the tool have a dual effect. If the cutting wedge angle is changed in order to increase the stability of the cutting wedge, chip formation is impaired and cutting forces and tool wear increase. If the chip formation is improved by changing the angle, the stability of the cutting wedge decreases. Each definition of a tool angle therefore represents a compromise that only partially meets the various requirements.

This is the only way to understand the recommendations for cutting wedge geometry given in guideline tables. The recommended cutting wedge geometry must always be modified according to operational experience if other influences are to be taken into account. In such cases it is

important to know in which direction cutting angle changes influence the machinability parameters. However, due to major advances in the field of cutting materials, changes to the cutting wedge geometry with the aim of improving wear behavior are now only of secondary importance. The focus is on angle changes to improve chip formation and chip evacuation.

For copper materials, the clearance angles are usually between 6° and 8° for high-speed steel and between 8° and 10° for carbide. Large clearance angles reduce flank wear and allow the cutting wedge to penetrate the workpiece more easily. If the wear mark width VB is kept constant, small increases in the clearance angle

clearance angle increase the service life of the cutting edge, as the wear volume increases.

More time is required to remove a larger volume of wear, so the tool life increases. However, the possibility of increasing the clearance angle is limited by the weakening of the cutting wedge. This leads to heat build-up in the cutting edge tip and thus to the risk of the cutting edge breaking out, and the moment of resistance to bending also decreases sharply as the clearance angle increases.

The rake angle γ_0 is the most important of all tool angles. The size of the deformation and cutting work during chip formation depends on the rake angle. The rake angles for copper materials vary in a wide range between 0° and 25°.

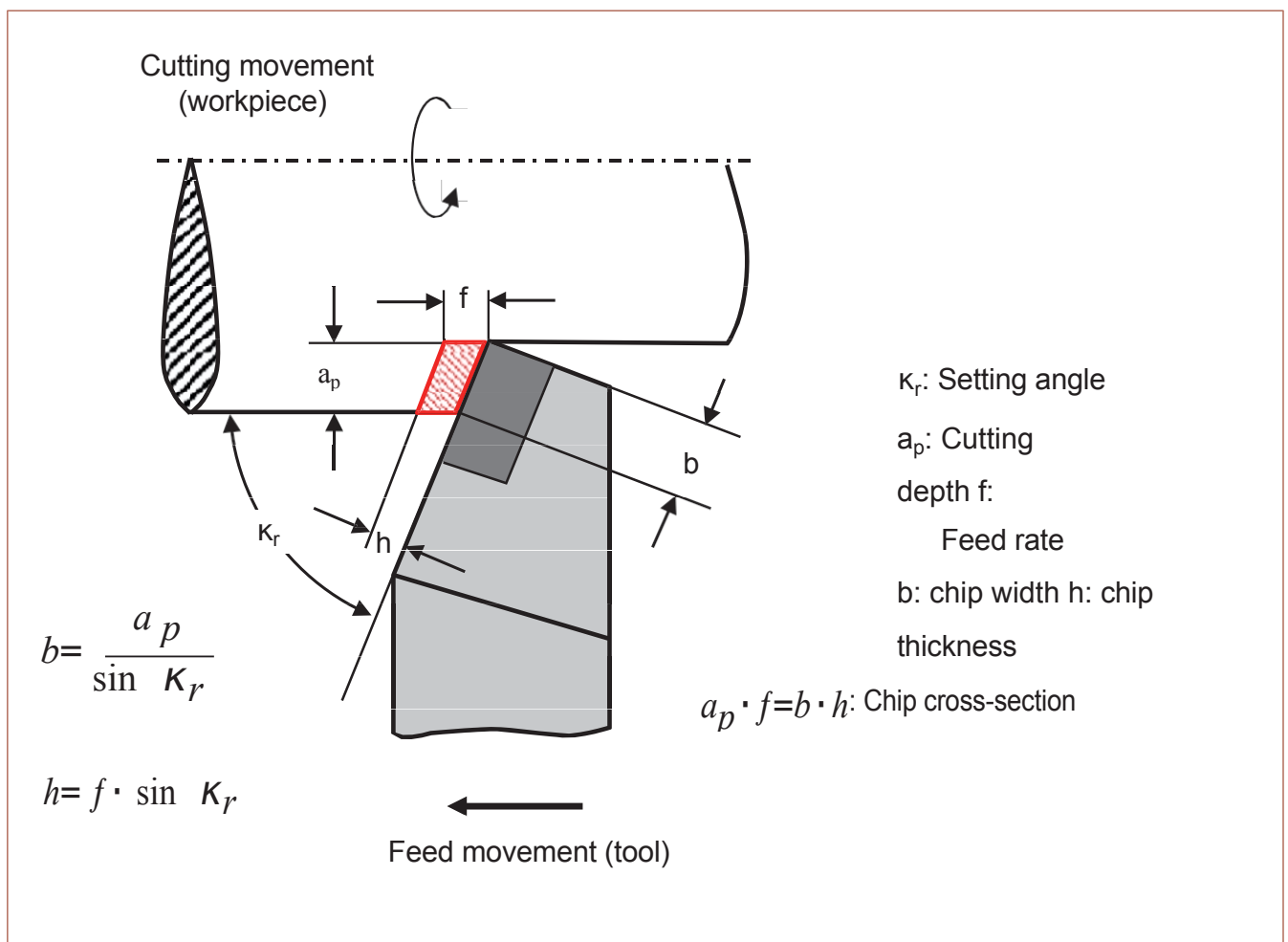

Fig. 6: Engagement ratios for longitudinal rotary turning (according to DIN 6580)